

VM-K Type High Frequency & Ultra Low Noise 3.2 x 2.5 mm Differential Output Voltage Controlled Crystal Oscillator

FEATURES

- MSL : Level 1
- Pb-free/RoHS Compliant
- Tri-state Enable / Disable Mode
- Temperature Range: -40 to 85 °C
- Clock Output: LVPECL, LVDS, CML, HCSSL
- Output Frequency Support from 15MHz to 2.1GHz
- Low Power Supply Voltage: 3.3, 2.5, and 1.8V Supply Options
- Ultra Low Phase RMS jitter: Typical: 150fs at 12kHz to 20MHz Frequency Offsets

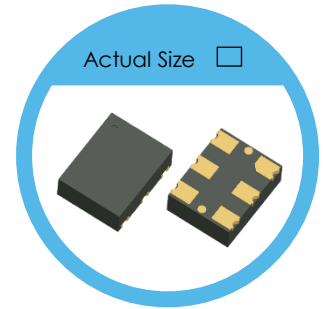

RoHS Compliant

TYPICAL APPLICATION

- Defense Systems
- Mobile Radar Station
- Gigabit Ethernet, SONET/SDH
- Server & Storage, Data Center
- SD/HD Video, FPGA Clock Generation

DIMENSION (mm)

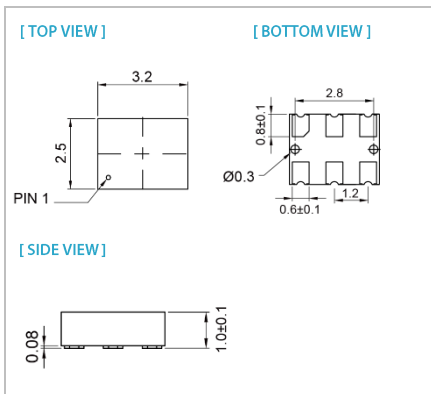

SOLDER PAD LAYOUT (mm)

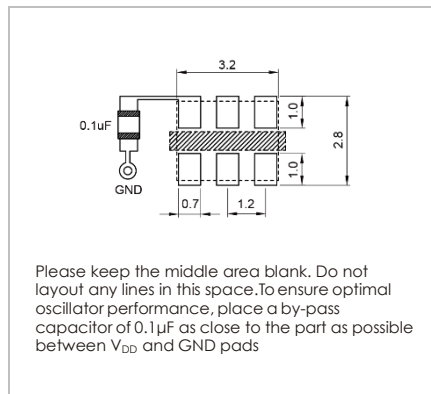

PIN FUNCTION (mm)

PIN#	FUNCTION
	LVPECL/LVDS/HCSSL/CML
1	VC
2	OE
3	GND
4	OUTPUT
5	OUTPUT_N
6	V _{DD}

ELECTRICAL SPECIFICATION

Parameter	LVPECL				Unit	Test Condition
	3.3V		2.5V			
	Min.	Max.	Min.	Max.		
Supply Voltage Variation (V _{DD}) \pm 10%	2.97	3.63	2.25	2.75	V	
Frequency Range	15	2100	15	2100	MHz	
Standard Frequency	155.52, 122.88, 187.5, 212.5, 266.667, 312.5, 622.08, 644.53125				MHz	
Supply Current	110		95		mA	
Output Level	Output High	V _{DD} - 1.165	V _{DD} - 0.8	V _{DD} - 1.165	V _{DD} - 0.8	V
	Output Low	V _{DD} - 2.0	V _{DD} - 1.55	V _{DD} - 2.0	V _{DD} - 1.55	V
Transition Time (20% - 80%)	Rise Time	0.35		0.35		nSec
	Fall Time	0.35		0.35		nSec
Duty Cycle	45	55	45	55	%	
Startup Time	8		8		mSec	
Tri-State Mode (Input to Pin 2)	Enable	0.7 x V _{DD}		0.7 x V _{DD}		V
	Disable	0.3 x V _{DD}		0.3 x V _{DD}		V
Stand by Current	110		95		mA	
Phase Noise	Typ.	Max.		Typ.	Max.	
	At V _{DD} =3.3V, f _{out} =873.515MHz	1kHz offset	-106	-106		dBc/Hz
	10kHz offset	-115	-115		dBc/Hz	
	100kHz offset	-123	-123		dBc/Hz	
	1MHz offset	-133	-133		dBc/Hz	
	20MHz offset	-150	-150		dBc/Hz	
RMS Phase Jitter (Integrated 12 kHz-20 MHz)	150	300	150	300	fs	
Period Jitter	50		50		ps	

Note: not all combination of options are available. Other specifications may be available upon request.

Specifications subject to change without notice.

Parameter	LVDS						Unit	Test Condition	
	3.3V		2.5V		1.8V				
	Min.	Max.	Min.	Max.	Min.	Max.			
Supply Voltage Variation (V _{DD})	2.97	3.63	2.25	2.75	1.71	1.89	V		
Frequency Range	15	2100	15	2100	15	2100	MHz		
Standard Frequency	155.52, 122.88, 187.5, 212.5, 266.667, 312.5, 622.08, 644.53125						MHz		
Supply Current		90		80		70	mA		
Output Level	Output High		1.6		1.6		1.6	V	
	Output Low	0.9		0.9		0.9		V	
Transition Time (20% – 80%)	Rise Time		0.35		0.35		0.35	nSec	
	Fall Time		0.35		0.35		0.35	nSec	
Duty Cycle	45	55	45	55	45	55	%		
Startup Time		8		8		8	mSec		
Tri-State Mode (Input to Pin 2)	Enable	0.7 x V _{DD}		0.7 x V _{DD}		0.7 x V _{DD}		V	
	Disable		0.3 x V _{DD}		0.3 x V _{DD}		0.3 x V _{DD}	V	
Stand by Current		90		80		70	mA		
Phase Noise	Typ.	Max.	Typ.	Max.	Typ.	Max.			
At V _{DD} =3.3V, f _{out} =873.515MHz	1kHz offset	-106		-106		-106		dBc/Hz	
	10kHz offset	-115		-115		-115		dBc/Hz	
	100kHz offset	-123		-123		-123		dBc/Hz	
	1MHz offset	-133		-133		-133		dBc/Hz	
	20MHz offset	-150		-150		-150		dBc/Hz	
RMS Phase Jitter (Integrated 12 kHz~20 MHz)	150	300	150	300	150	300	fs		
Period Jitter		50		50		50	ps		

Parameter	HCSL						Unit	Test Condition	
	3.3V		2.5V		1.8V				
	Min.	Max.	Min.	Max.	Min.	Max.			
Supply Voltage Variation (V _{DD})	2.97	3.63	2.25	2.75	1.71	1.89	V		
Frequency Range	15	700	15	700	15	700	MHz		
Standard Frequency	155.52, 122.88, 187.5, 212.5, 266.667, 312.5, 622.08, 644.53125						MHz		
Supply Current		90		80		70	mA		
Output Level	Output High	0.66	1.15	0.66	1.15	0.66	1.15	V	
	Output Low	0	0.15	0	0.15	0	0.15	V	
Transition Time (20% – 80%)	Rise Time		0.35		0.35		0.35	nSec	
	Fall Time		0.35		0.35		0.35	nSec	
Duty Cycle	45	55	45	55	45	55	%		
Startup Time		8		8		8	mSec		
Tri-State Mode (Input to Pin 2)	Enable	0.7 x V _{DD}		0.7 x V _{DD}		0.7 x V _{DD}		V	
	Disable		0.3 x V _{DD}		0.3 x V _{DD}		0.3 x V _{DD}	V	
Stand by Current		90		80		70	mA		
Phase Noise	Typ.	Max.	Typ.	Max.	Typ.	Max.			
At V _{DD} =3.3V, f _{out} =805.664MHz	1kHz offset	-107		-107		-107		dBc/Hz	
	10kHz offset	-117		-117		-117		dBc/Hz	
	100kHz offset	-125		-125		-125		dBc/Hz	
	1MHz offset	-135		-135		-135		dBc/Hz	
	20MHz offset	-150		-150		-150		dBc/Hz	
RMS Phase Jitter (Integrated 12 kHz~20 MHz)	150	300	150	300	150	300	fs		
Period Jitter		50		50		50	ps		

Parameter	CML						Unit	Test Condition	
	3.3V		2.5V		1.8V				
	Min.	Max.	Min.	Max.	Min.	Max.			
Supply Voltage Variation (V _{DD})	2.97	3.63	2.25	2.75	1.71	1.89	V		
Frequency Range	15	2100	15	2100	15	2100	MHz		
Standard Frequency	155.52, 122.88, 187.5, 212.5, 266.667, 312.5, 622.08, 644.53125						MHz		
Supply Current		90		80		70	mA		
Output Level	Output High	V _{DD} – 0.085	V _{DD}	V _{DD} – 0.085	V _{DD}	V _{DD} – 0.085	V _{DD}	V	
	Output Low	V _{DD} – 0.6	V _{DD} – 0.32	V _{DD} – 0.6	V _{DD} – 0.32	V _{DD} – 0.6	V _{DD} – 0.32	V	
Transition Time (20% – 80%)	Rise Time		0.35		0.35		0.35	nSec	
	Fall Time		0.35		0.35		0.35	nSec	
Duty Cycle	45	55	45	55	45	55	%		
Startup Time		8		8		8	mSec		
Tri-State Mode (Input to Pin 2)	Enable	0.7 x V _{DD}		0.7 x V _{DD}		0.7 x V _{DD}		V	
	Disable		0.3 x V _{DD}		0.3 x V _{DD}		0.3 x V _{DD}	V	
Stand by Current		90		80		70	mA		
Phase Noise	Typ.	Max.	Typ.	Max.	Typ.	Max.			
At V _{DD} =3.3V, f _{out} =805.664MHz	1kHz offset	-107		-107		-107		dBc/Hz	
	10kHz offset	-117		-117		-117		dBc/Hz	
	100kHz offset	-125		-125		-125		dBc/Hz	
	1MHz offset	-135		-135		-135		dBc/Hz	
	20MHz offset	-150		-150		-150		dBc/Hz	
RMS Phase Jitter (Integrated 12 kHz~20 MHz)	150	300	150	300	150	300	fs		
Period Jitter		50		50		50	ps		

Note: not all combination of options are available. Other specifications may be available upon request.

Specifications subject to change without notice.

Parameter	Control Voltage Function on Pin 1						Unit	Test Condition
	3.3V		2.5V		1.8V			
	Min.	Max.	Min.	Max.	Min.	Max.		
Control Voltage Center	1.65		1.25		0.9		V	
Control Voltage Range	0.3	3	0.25	2.25	0.18	1.62	V	
Frequency Pulling Range	±50	±250	±50	±250	±50	±250	ppm	
Linearity		±10		±10		±10	%	
Modulation Bandwidth	5	20	5	20	5	20	KHz	
VC Input Impedance	5		5		5		MΩ	

FREQ. STABILITY vs. TEMP. RANGE

Temp.(°C)	ppm	±20	±25	±50	±100
	-10 ~ +60		○	○	○
-20 ~ +70		△	○	○	○
-40 ~ +85		×	△	○	○

○: Available △:Conditional ×: Not Available
 Inclusive of calibration @ 25°C ,operating temperature range,input
 Voltage variation,load variation,aging (1st year),shock,and vibration

Note: not all combination of options are available. Other specifications may be available upon request.

Specifications subject to change without notice.